

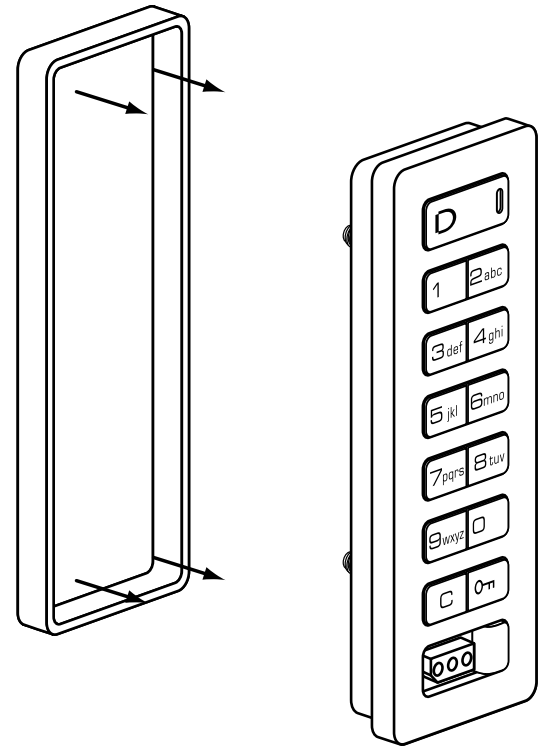

DIGILOCK INSTALLATION INSTRUCTIONS
VERTICAL BODY
SURFACE MOUNT
12-16 GAUGE DOOR

STEP 1

PLACE THE PLASTIC RING (B) ONTO THE FRONT UNIT (D).



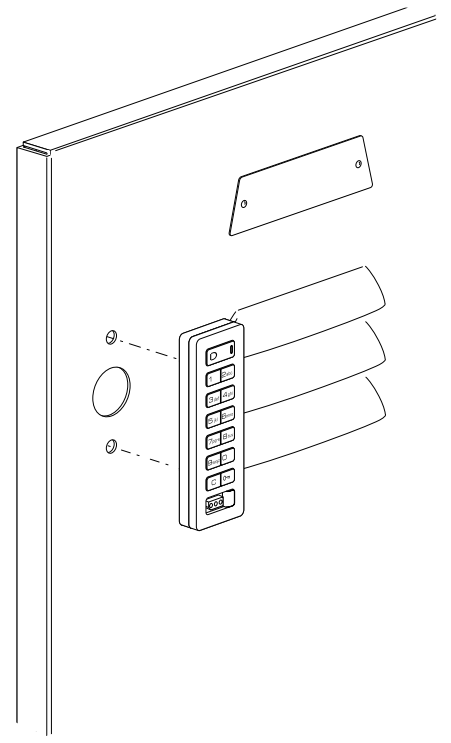

STEP 3

PLACE THE MOUNTING SCREW POSTS OF THE DIGILOCK FRONT UNIT (D) THROUGH THE LOCK MOUNTING HOLES ON THE FRONT OF THE DOOR.

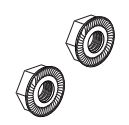

INCLUDED COMPONENTS:

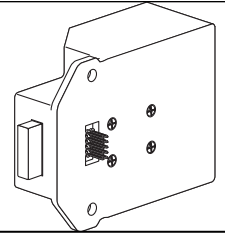
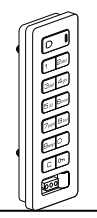
			
(A) 2 - LOCKING NUTS	(B) 1 - PLASTIC RING	(C) 1 - REAR UNIT	(D) 1 - FRONT UNIT

TOOLS REQUIRED:

3/8" SOCKET ATTACHED TO A SCREW GUN OR RATCHET

STEP 2

LOCATE THE THREE LOCK MOUNTING HOLES ON THE LOCKER DOOR. REMOVE THE HOLE BLOCKING PLATE (IF ANY) TO EXPOSE THE HOLES.

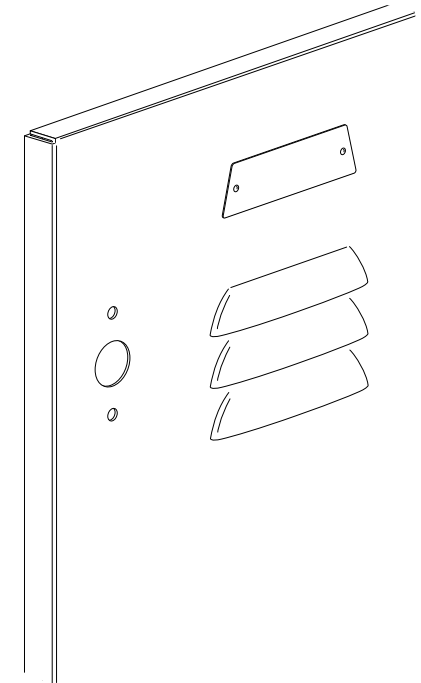

STEP 4

WHILE HOLDING THE FRONT UNIT AGAINST THE FRONT OF THE DOOR, PLACE THE REAR UNIT (C) AGAINST THE REAR FACE OF THE DOOR, ALIGNING ITS MOUNTING HOLES WITH THE MOUNTING SCREW POSTS FROM THE FRONT UNIT.

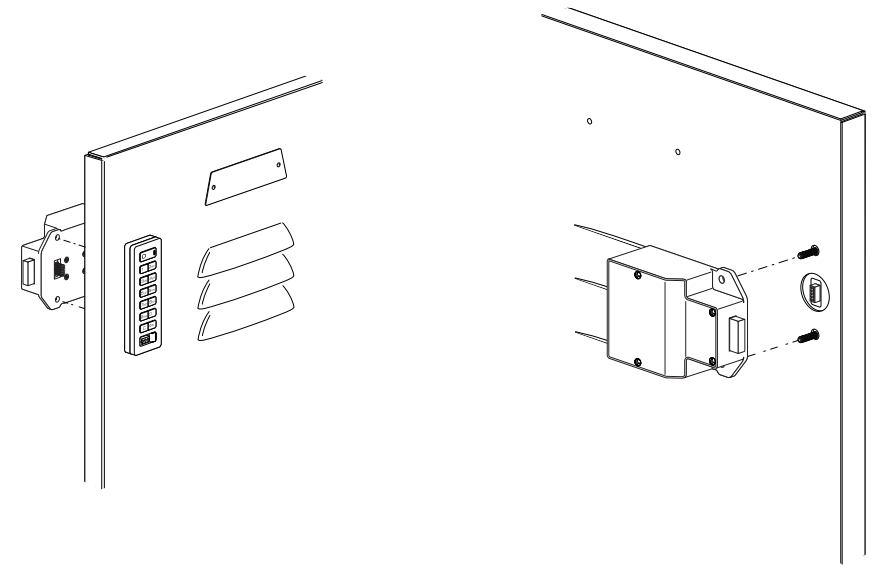

NOTE: DO NOT TOUCH THE REAR UNIT CONNECTOR PINS (MALE CONNECTOR) AGAINST ANY METAL OR OTHER CONDUCTIVE SURFACES. THIS MAY SHORT THE BATTERIES AND CAUSE DAMAGE TO THE LOCK.

WARNING: DO NOT USE AN ELECTRIC SCREW GUN UNLESS EQUIPPED WITH A TORQUE ADJUSTER, WHICH MUST BE SET ON A LOW TORQUE SETTING. OTHERWISE, DAMAGE MAY BE CAUSED TO THE LOCK.

STEP 5

SLIDE THE FRONT UNIT (D) AND REAR UNIT (C) TOGETHER MAKING SURE THAT THE PINS OF THE REAR UNIT CONNECTOR ALIGN WITH THE FRONT UNIT (D) CONNECTOR.

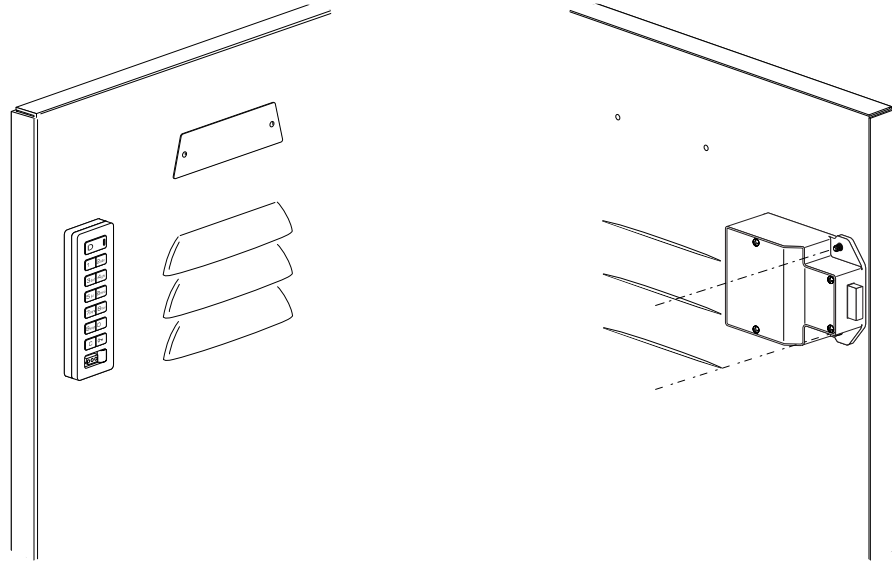

NOTE: AN AUDIBLE TRIPLE BEEP AND THREE FLASHES OF THE LED INDICATES THAT THE LOCK WAS CONNECTED PROPERLY. IF YOU DO NOT HEAR THIS BEEP, REMOVE THE FRONT UNIT, PRESS THE "C" BUTTON AND RECONNECT THE FRONT AND REAR UNITS.

STEP 7

TEST THE OPERATION SEVERAL TIMES WHILE THE DOOR IS OPEN. CLOSE THE DOOR AND TEST THE UNIT AGAIN. MAKE SURE THERE IS NO BINDING BETWEEN THE BOLT AND THE DOOR'S STRIKE PLATE AND/OR FRAME. ADJUST THE LOCKER IF NECESSARY.

TO LOCK AND UNLOCK ENTER:



NOTE: IF DURING OPERATION OF THE LOCK, THE LOCK EMITS 10 RAPID BEEPS AND 10 FLASHES OF THE LED, IT IS AN INDICATOR THAT THE BOLT OF THE LOCK IS BINDING WITH THE DOOR'S STRIKE PLATE AND/OR FRAME.

FOR ADDITIONAL PRODUCT AND/OR PRODUCT INFORMATION

CONTACT DIGILOCK OR YOUR DIGILOCK RESELLER.

STEP 6

PLACE THE LOCKING NUTS (A) OVER THE MOUNTING SCREWS AND TIGHTEN TO SECURE THE LOCK TO THE DOOR. (DO NOT OVERTIGHTEN).

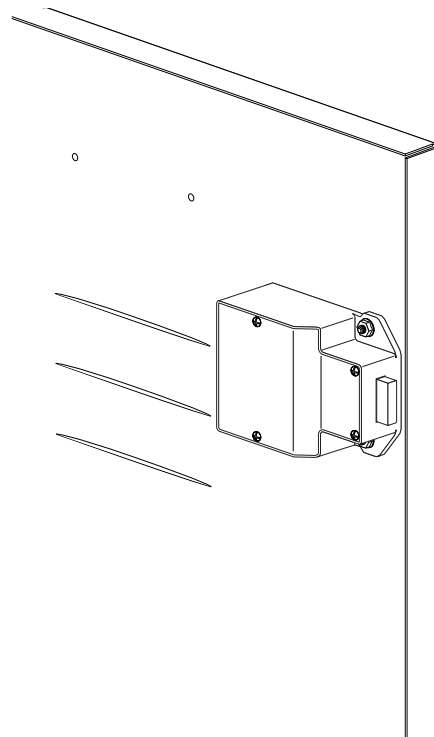

INSTALLATION COMPLETE

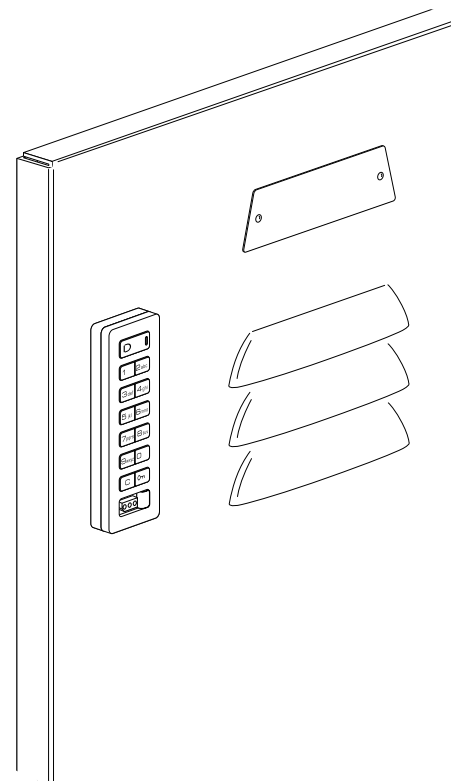

DigiLock[®]
www.digilock.com

5341 OLD REDWOOD HIGHWAY, SUITE 200
PETALUMA, CA 94954

PHONE: (800) 989.0201 OR (707) 766.6000
FAX: (800) 986.4221 OR (707) 766.6226