

TROUBLESHOOTING GUIDE

PROBLEM:

THE LOCK OPERATES WITH  AND DOES NOT RECOGNIZE ANY CODES/KEYS.

- A) THE LOCK HAS NOT BEEN INITIALIZED. REFER TO THE OPERATING/PROGRAMMING GUIDE TO INITIALIZE THE LOCK.

NO AUDIBLE FEEDBACK WHEN  BUTTON IS PRESSED:

- A) THE LOCK IS IN "SLEEP STATE." WAIT ONE MINUTE AND TRY AGAIN.
- B) THE BATTERIES HAVE FAILED- USE MANAGER BYPASS KEY TO UNLOCK THE LOCK AND REPLACE BATTERIES LOCATED IN THE REAR UNIT.
- C) POOR CONNECTION ON DOOR- REMOVE LOCK FROM DOOR AND REINSTALL.

PROBLEM:

LOCK DOES NOT UNLOCK:

- A) LISTEN FOR ADDITIONAL AUDIBLE FEEDBACK FOR AN INDICATOR AS TO WHAT IS GOING ON.
- B) TRY OPERATING WITH MANAGER BYPASS KEY OR PROGRAMMING KEY
- C) CONTACT YOUR DIGILOCK PRODUCT REPRESENTATIVE OR DIGILOCK CUSTOMER SUPPORT.

ONE BEEP AND ONE RED FLASH OCCURS WHEN INSERTING MANAGER BYPASS KEY, USER KEY AND/OR PROGRAMMING KEY.

- A) THE KEY IS NOT RECOGNIZED BY THE LOCK. TRY ANOTHER KEY OR REFER TO LOCK PROGRAMMING INSTRUCTIONS TO REGISTER THE KEY TO THE LOCK.

CHANGING THE BATTERIES

1) THE BATTERIES ARE LOCATED IN THE REAR UNIT OF THE LOCK. TO CHANGE THE BATTERIES, REMOVE THE REAR UNIT COVER PLATE:

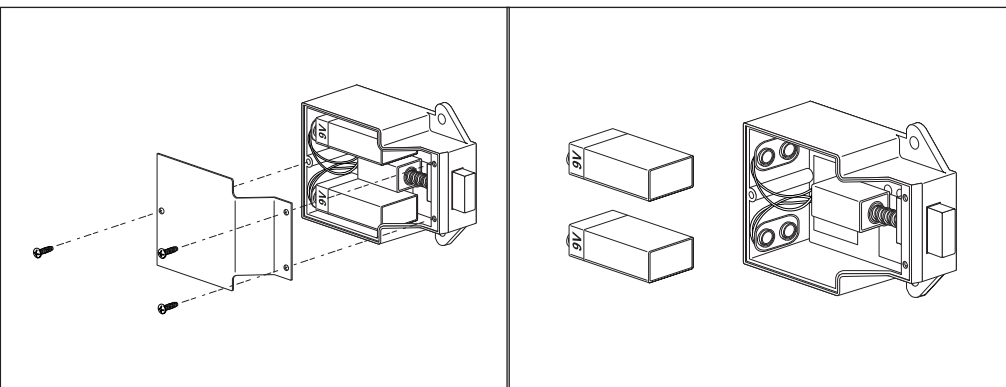

2) REMOVE EXISTING BATTERIES AND REPLACE WITH NEW BATTERIES. DEPENDING ON LOCK MODEL, YOUR LOCK WILL REQUIRE 2 "9-VOLT" BATTERIES, 4 "AA" BATTERIES OR 4 "AAA" BATTERIES.

NOTE: TO ACHIEVE OPTIMAL BATTERY LIFE USE PREMIUM ALKALINE BATTERIES.

3) REPLACE THE REAR UNIT COVER PLATE AND TEST THE DIGILOCK.

LOCK INDICATORS

LOCK EMITS 2 SETS OF THREE BEEPS DURING OPERATION:

- A) LOW BATTERY INDICATOR
 - i) REPLACE BATTERIES LOCATED IN THE REAR UNIT.
 - ii) IF BATTERIES FAIL IN THE LOCKED POSITION, THE MANAGER BYPASS KEY AND PROGRAMMING KEY WILL SUPPLY BYPASS POWER TO THE LOCK. USE THE MANAGER BYPASS KEY OR PROGRAMMING KEY TO UNLOCK THE LOCK AND REPLACE BATTERIES IMMEDIATELY.

LOCK EMITS 10 RAPID BEEPS DURING OPERATION:

- A) BINDING INDICATOR
 - i) IF THE LOCK IS LOCKED, THE LOCK IS BINDING WITH THE STRIKE PLATE OR THE ITEMS IN THE LOCKER. PRESS FIRMLY ON THE DOOR WHILE OPERATING. IF BINDING IS A FREQUENT OCCURRENCE, THE STRIKE PLATE AND/OR DOOR HINGES NEED TO BE ALIGNED WITH THE LOCK.
 - ii) IF THE LOCK IS UNLOCKED, THE SCREWS/LOCKING NUTS MAY BE OVERTIGHTENED. LOOSEN THE SCREWS/LOCKING NUTS AND TRY TO OPERATE. IF BINDING INDICATOR IS STILL HEARD, REMOVE LOCK FROM DOOR. ASSEMBLE LOCK IN HANDS AND TEST OPERATION. IF THE LOCK WORKS, REINSTALL ON DOOR. IF THE LOCK STILL GIVES THE BINDING INDICATOR, CONTACT DIGILOCK CUSTOMER SUPPORT.

FOR ADDITIONAL PRODUCT AND/OR PRODUCT INFORMATION:

VISIT: WWW.DIGILOCK.COM

E-MAIL: SUPPORT@DIGILOCK.COM

CONTACT: DIGILOCK OR YOUR DIGILOCK PRODUCT REPRESENTATIVE



DigiLock[®]
www.digilock.com

5341 OLD REDWOOD HIGHWAY, SUITE 200
PETALUMA, CA 94954

PHONE: (800) 989.0201 – (707) 766.6000

FAX: (800) 986.4221 – (707) 766.6226