

Installation Instructions

Digilock KT-s Surface Mount

Door Preparation: Before Installing Digilock you must prep your door by following these steps:

1. Install a Strike Plate (used to engage bolt/latch while locked)
2. Drill lock mounting holes
3. Install your lock
4. Test the units operation

1 Install either a Security Strike or L Bracket strike plate (not provided) on your door as shown in Figure 1. Be sure you install the strike plate at the same height as you would like lock. If you need to order strike plates, contact a Digilock sales representative.

2 Follow the directions on the "Wood Door Hole Template" on page 3 and use Figure 2 (lock mounting hole template) below to drill your lock mounting holes.

FIGURE 1

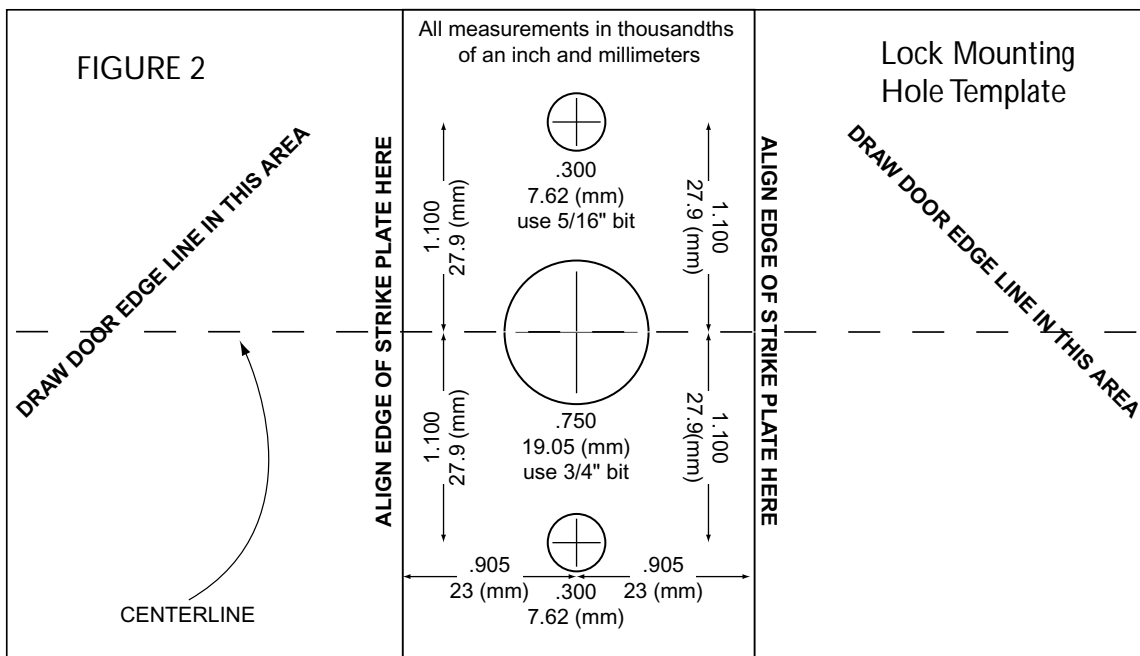
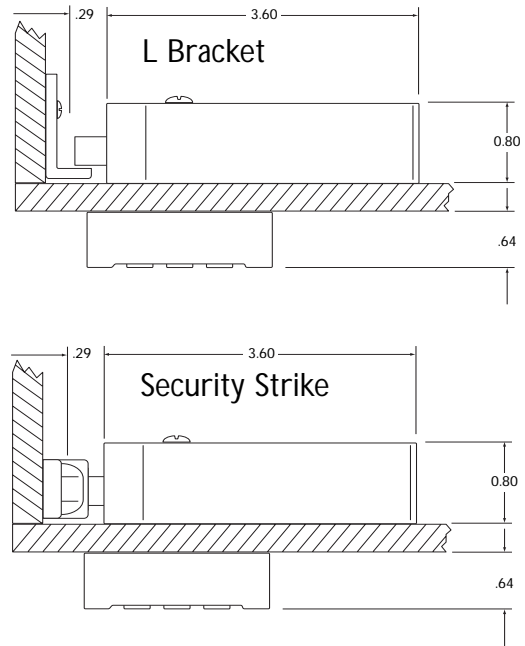

WARNING: Do not touch the rear unit connector against metal or other conductive surfaces. This may short the pin and cause damage to the lock. (See Figure 3)

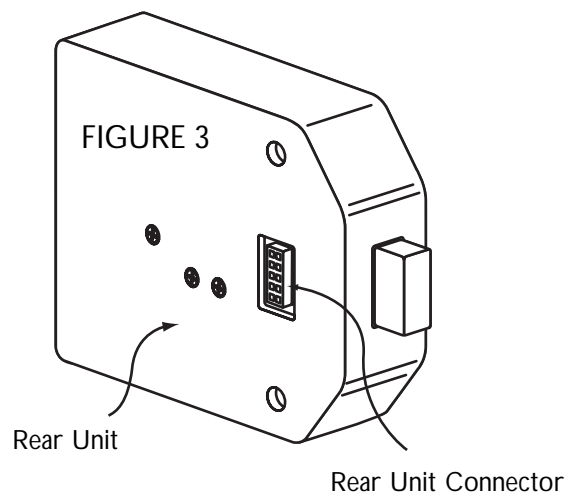

3 Attach the pin extender to the end of the front unit connector. **Do not attach the pin extender to the rear unit.** Be sure to align the 10 pins of the pin extender to the 10 positions of the front unit connector. (See Figure 4)

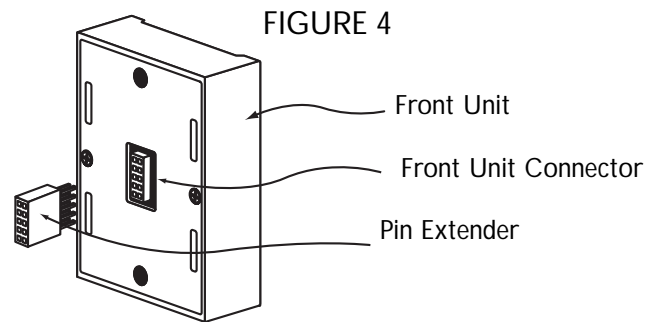

Place the rear unit against the rear face of the door, aligning its mounting holes with the door. (See Figure 5)

Attach the lock washers to the mounting screws (10-24) then place the mounting screws through the mounting holes. At this point, you should be able to see the tips of the mounting screws from the front face of the locker door.

FIGURE 5

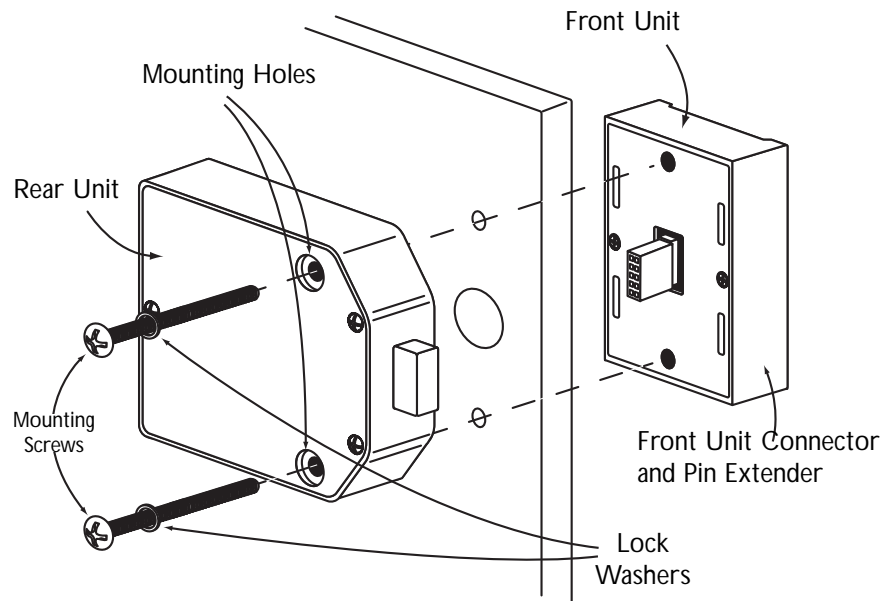

Place the front unit on the front face of the door connecting it with the rear unit. Make sure to align the pins of the rear unit connector with the extender of the front unit connector. An audible triple beep indicates that the lock was connected properly. If you do not hear this beep, reconnect the front and rear units. Tighten the mounting screws. (See Figure 5)

4 Test the unit's operation several times while the door is open. Close the door and test the unit again. Make sure there is no binding between the latch and the door's strike plate or frame.

Wood Door Hole Template Instructions

2 Using a pencil, mark the door edge on the template and also mark the centerline on the door edge. Open door, remove template.

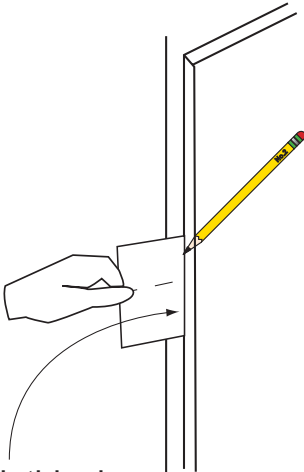

Mark this door edge on the paper template

1

Center the template over the strike plate and align edge of strike plate with the line on template, and close door while holding the template in place

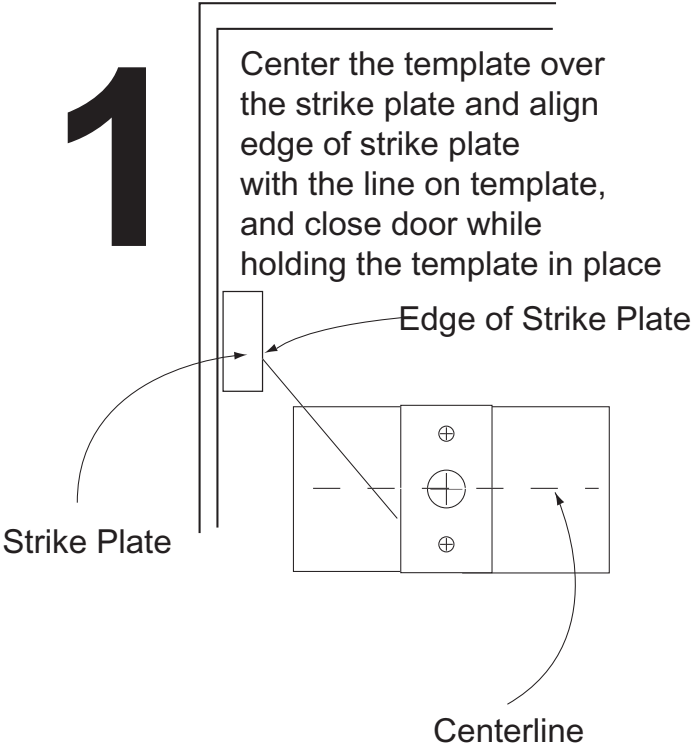

3

Place the template over the door aligning it with the centerline on the template and the centerline mark you made on the door edges as well as aligning the door edge with the door edge you made on the template.

Mark the centers of all three holes and drill the holes as defined on the template.

